

THANK YOU

for purchasing the Ninja® Flip 10-in-1 Toaster Oven & Air Fryer



REGISTER YOUR PURCHASE



registeryourninja.com



Scan QR code using mobile device

RECORD THIS INFORMATION

Model Number: _____

Serial Number: _____

Date of Purchase: _____
(Keep receipt)

Store of Purchase: _____

TECHNICAL SPECIFICATIONS

Voltage: 120V-, 60Hz

Power: 1800 Watts

SharkNinja Operating LLC

US: Needham, MA 02494

1-877-646-5288

ninjakitchen.com

Illustrations may differ from actual product. We are constantly striving to improve our products, therefore the specifications contained herein are subject to change without notice.

FOODI and NINJA are registered trademarks of SharkNinja Operating LLC.

The product may be covered by one or more U.S. patents.
See sharkninja.com/patents for more information.

© 2024 SharkNinja Operating LLC

FT405CO_IB_MP_Mv2_241122



@ninjakitchen







NINJA® FLIP 10-IN-1 TOASTER OVEN & AIR FRYER

FT405CO | Owner's Guide



IMPORTANT SAFETY INSTRUCTIONS

PLEASE READ ALL INSTRUCTIONS CAREFULLY BEFORE USE • FOR HOUSEHOLD USE ONLY

	Read and review instructions to understand operation and use of product.
	Indicates the presence of a hazard that can cause personal injury, death or substantial property damage if the warning included with this symbol is ignored.
	Avoid contact with hot surface. Always use hand protection to avoid burns.
	For indoor and household use only.

⚠ WARNING

To reduce the risk of injury, fire, electrical shock or property damage, basic safety precautions must always be followed, including the following numbered warnings and subsequent instructions. Do not use appliance for other than intended use.

- 1 Read all instructions prior to using the oven and its accessories.
- 2 To eliminate a choking hazard for young children, discard all packaging materials immediately upon unpacking.
- 3 This appliance can be used by persons with reduced physical, sensory or mental capabilities or lack of experience and knowledge if they have been given supervision or instruction concerning use of the appliance in a safe way and understand the hazards involved.
- 4 Take inventory of all contents to ensure you have all parts needed to properly and safely operate your oven.
- 5 **NEVER** leave the oven unattended while in use.
- 6 **NEVER** use outlet below counter.
- 7 **DO NOT** let cord hang over edges of tables or counters or touch hot surfaces, including stoves and other heating ovens.
- 8 Keep the appliance and its cord out of reach of children. Do not allow the appliance to be used by children. Close supervision is necessary when used near children.
- 9 **DO NOT** use an extension cord. A short power-supply cord is used to reduce the risk of children grabbing the cord or becoming entangled and to reduce the risk of people tripping over a longer cord.
- 10 **DO NOT** place appliance on hot surfaces, near hot gas or electric burner, in a heated oven or on a stovetop.
- 11 **DO NOT** place any object directly onto the heating elements and **DO NOT** cover crumb tray or any part of the oven with metal foil. This will cause the oven to overheat or cause a fire.
- 12 To protect against electrical shock
DO NOT immerse cord, plugs, or main unit housing in water or other liquid.
- 13 **DO NOT** use the oven with damage to the power cord or plug. Regularly inspect the oven and power cord. If the oven malfunctions or has been damaged in any way, immediately stop use and call Customer Service.
- 14 **DO NOT** cover the air intake vents or air outlet vents while unit is operating. Doing so will prevent even cooking and may damage the unit or cause it to overheat.
- 15 **DO NOT** insert anything in the intake and ventilation slots and do not obstruct them.
- 16 **DO NOT** use accessory and attachments not recommended or sold by SharkNinja.

IMPORTANT SAFETY INSTRUCTIONS

PLEASE READ ALL INSTRUCTIONS CAREFULLY BEFORE USE • FOR HOUSEHOLD USE ONLY

- 17 **DO NOT** place items on top of surface while unit is operating except for authorized recommended Ninja accessories.
- 18 Before placing any accessories into the oven ensure they are clean and dry.
- 19 Intended for countertop use only. **DO NOT** place the oven near the edge of a countertop. Ensure the surface is level, clean and dry.
- 20 This oven is for household use only **DO NOT** use outdoors. **DO NOT** use in moving vehicles or boats.
- 21 **DO NOT** use this oven for anything other than its intended use. Misuse may cause injury.
- 22 **DO NOT** store any materials, other than supplied accessories, in this oven when not in use.
- 23 When using this oven, provide adequate space above and on all sides for air circulation.
- 24 A fire may occur if the oven is covered or touching flammable material, including curtains, draperies, walls, or the like when in operation. **DO NOT** place anything on the oven during operation.
- 25 This oven has a tempered glass door and is more resistant to breakage. Avoid scratching door surface or nicking edges.
- 26 **DO NOT** use the unit without the crumb tray installed. Ensure crumbs are removed and the tray is cleaned before each use.
- 27 **DO NOT** use the oven without the wire rack or air fry basket installed.
- 28 **DO NOT** spray any type of aerosol spray or flavoring inside the oven while cooking.
- 29 Use caution when inserting and removing anything from the oven, especially when hot.
- 30 **DO NOT** use parchment on Broil or above the recommended manufacturers instructions.
- 31 Voltages can vary, affecting the performance of your product. To prevent possible illness, use an external thermometer to check that your food is cooked to the temperatures recommended.
- 32 Prevent food contact with heating elements. Excessive food loads may cause personal injury or property damage or affect the safe use of the oven.
- 33 **DO NOT** place any of the following materials in the oven: paper, cardboard, plastic, roasting bags and the like.
- 34 Extreme caution should be exercised when using containers constructed of any materials other than metal or glass.
- 35 **DO NOT** touch hot surfaces. Oven surfaces are hot during and after operation. To prevent burns or personal injury, **ALWAYS** use protective hot pads or insulated oven mitts and use available handles and knobs.
- 36 Spilled food can cause serious burns. Extreme caution must be used when the oven contains hot food. Improper use may result in personal injury.
- 37 Please refer to the Cleaning & Maintenance section for regular maintenance of the oven.
- 38 Cleaning and user maintenance shall not be made by children.
- 39 Press the power button to turn oven off and allow to cool completely before cleaning, moving and flipping for storage.
- 40 Unplug from outlet when not in use. To unplug, grasp the plug by the body and pull from the outlet. Never unplug by grasping and pulling the flexible cord.
- 41 **DO NOT** clean with metal scouring pads. Pieces can break off the pad and touch electrical parts, causing a risk of electrical shock.
- 42 **DO NOT** use the oven as a source of heat or for drying.
- 43 This appliance has important markings on the plug blade. The entire supply cord is not suitable for replacement. If damaged, please contact SharkNinja for service.

SAVE THESE INSTRUCTIONS

PARTS & ACCESSORIES

- A Main Unit**
(attached power cord not shown)
- B Air Fry Basket**
Use in the top rail position for Air Fry and Dehydrate. Hand-wash recommended.
- C Broil Rack**
Place inside sheet pan. Hand-wash recommended.
- D Sheet Pan**
Always layer on top of wire rack. Hand-wash recommended.
- E Wire Rack**
Slide into bottom rails for Toast and Bagel. Hand-wash recommended.
- F Removable Crumb Tray**
Always place below the bottom heating element. Hand-wash only.

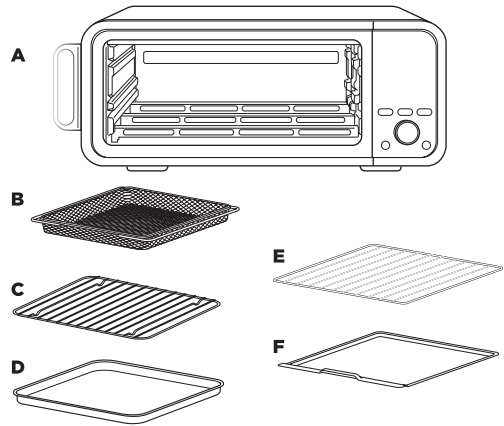

TIP: There is a hook on the left side of the bottom rails of the oven. This mechanism is designed to stabilize the wire rack when pulling out of oven partially.

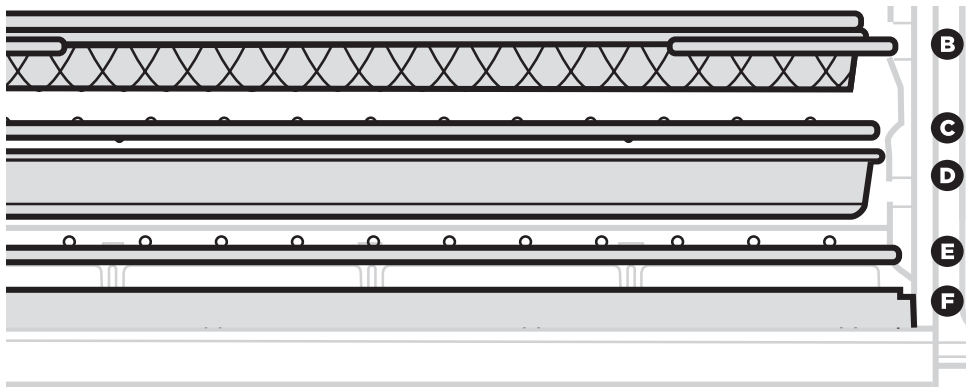

BEFORE FIRST USE

- 1** Remove and discard any packaging material, promotional labels, and tape from the unit.
- 2** Remove all accessories from the package and read this manual carefully. Please pay particular attention to operational instructions, warnings, and important safeguards to avoid any injury or property damage.
- 3** Wash the air fry basket, sheet pan, wire rack, broil rack, and removable crumb tray in warm, soapy water, then rinse and dry thoroughly with non-abrasive sponge. **DO NOT** place the sheet pan in the dishwasher.
- 4** **NEVER** submerge the main unit in water or place in dishwasher.

We recommend placing the wire rack, sheet pan, and air fry basket inside the oven and running it on Air Fry at 450°F for 20 minutes without adding food. Make sure the area is well ventilated. This removes any packaging residue and odor traces that may be present. This is completely safe and not detrimental to the performance of the oven.

NOTE: For longest use, we recommend hand-washing the accessories. The air fry basket and wire rack can be put in the dishwasher, but this may cause them to wear more quickly over time.

USING THE CONTROL PANEL

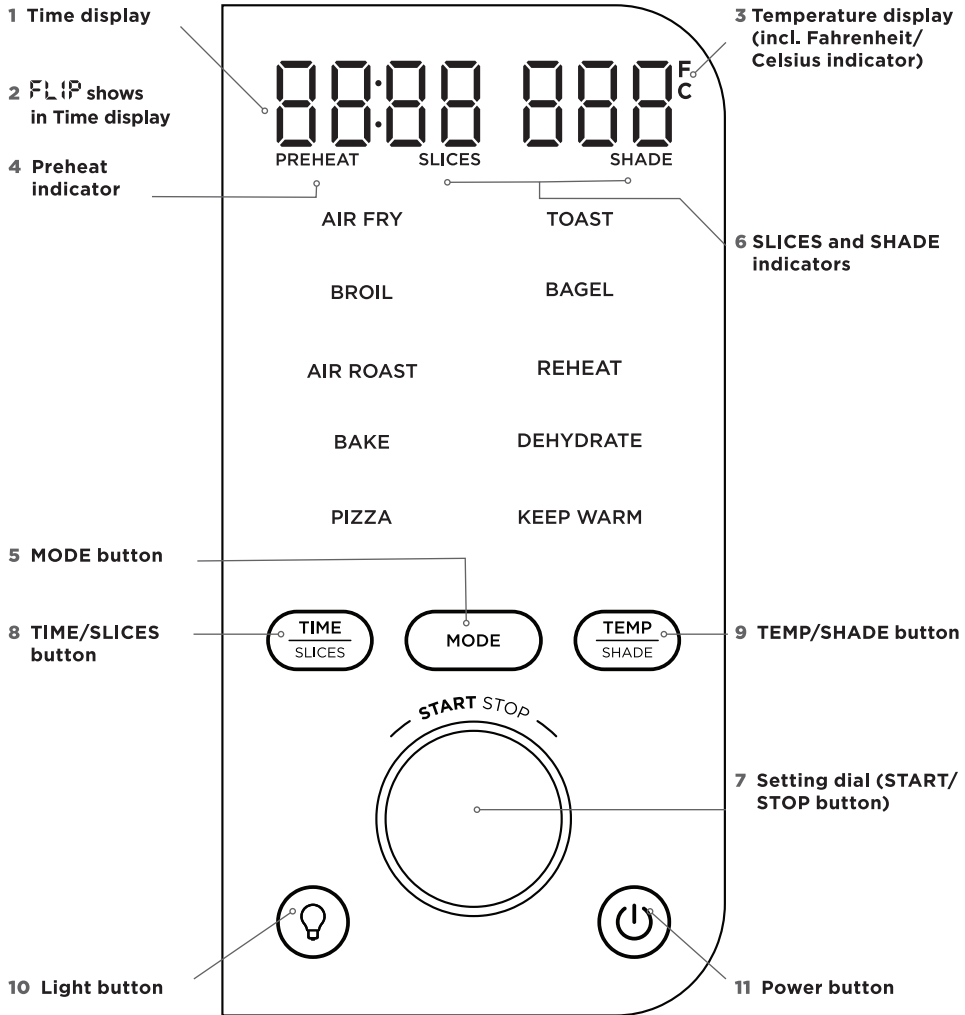

FUNCTIONS

AIR FRY: Make fast, extra-crispy foods—such as chicken wings, French fries, and chicken nuggets—with little to no added oil.

BROIL: Broils meat and fish and evenly browns the tops of casseroles.

AIR ROAST: Achieve a crispy outside and perfectly cooked inside for full-sized sheet pan meals, thicker proteins, and roasted veggies.

BAKE: Evenly bakes cookies, brownies, cakes, and more.

PIZZA: Cook frozen or homemade pizza evenly.

TOAST: Evenly toasts up to 9 slices of bread to your perfect level of darkness.

BAGEL: Perfectly toast up to 6 bagel halves when they're placed cut-side up on the wire rack.

REHEAT: Heat leftovers without over cooking.

DEHYDRATE: Dehydrates meats, fruits, and vegetables for healthy snacks.

KEEP WARM: Keeps food warm up to 2 hours.

CONTROL PANEL DISPLAY & OPERATING BUTTONS

- 1 Time display:** Shows the cook time. The time will count down when cooking is in progress.
- 2 FLIP** will appear on the time display when the unit is cool enough to flip up for storage or cleaning.
- 3 Temperature display:** Shows the cook temperature.

NOTE: Time and temperature will always default to the cook time and temperature that was set the last time the oven was in use. On first use, the default time and temperature should be adjusted for your cook cycle. Refer to Inspiration Guide to learn more on best cook times and temperatures.

- 4 PREHEAT:** Illuminates when the unit is pre-heating.
- 5 MODE button:** Press to enable selection of a cooking function, then rotate dial to cycle through. Press MODE button again to confirm selection.
- 6 SLICES and SHADE** will illuminate when using the Toast or Bagel function.
- 7 Setting dial (START/STOP button):** Push to start or pause cooking, or rotate to adjust settings.

- 8 TIME/SLICES button:** To select a cook time, press the TIME/SLICES button, then use the dial to adjust the time. Press TIME/SLICES button again to confirm. When using the Toast or Bagel function, this button will adjust the number of slices instead of the time. If cooking for 1 hour or less, the clock will count down by minutes and seconds. If cooking for more than 1 hour, the clock will count down by hours and minutes.
- 9 TEMP/SHADE button:** To adjust temperature, press the TEMP/SHADE button and use the dial to adjust the temperature. Press TEMP/SHADE button again to confirm. When using the Toast or Bagel function, this button will adjust the darkness (SHADE) level instead of the temperature.

NOTE: The cook time and temperature may be adjusted at any time during the cooking cycle.

NOTE: To switch from Fahrenheit to Celsius, press and hold the TEMP/SHADE button for 5 seconds while the unit is not in cook mode.

- 10 Light (Light) button:** Press to turn the oven's interior light on and off. Light will automatically turn on when 1 minute of cook time remains.
- 11 Power (Power) button:** Press to turn the unit on and off.

USING YOUR NINJA® FLIP 10-IN-1 TOASTER OVEN & AIR FRYER

POWER CORD MANAGEMENT

Our cord-management system is designed so it will not interfere with the oven's flip-away functionality.

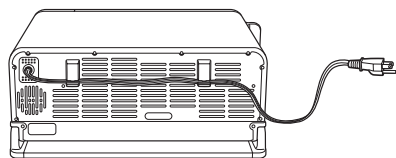

Option 1
Outlet on the left

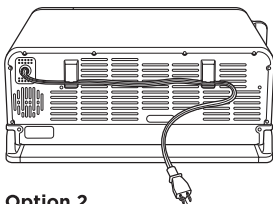

Option 2
Outlet behind the oven

HOW TO REDUCE SMOKE

When cooking greasy, drippy foods with the Air Fry Basket, place the sear plate on the bottom rails to catch the drippings.



Recommended:

Canola
Refined coconut
Avocado
Vegetable
Grapeseed

Not recommended

Olive oil
Butter
Margarine

- The unit may produce smoke when cooking on a hotter setting than what is recommended. Avoid exceeding 400°F when using oils to limit smoke.
- When using cooking spray, **DO NOT** spray it on the interior side walls or heating elements of the unit. Cooking spray may reduce life of product.

USING YOUR NINJA® FLIP 10-IN-1 TOASTER OVEN & AIR FRYER

USING THE COOKING FUNCTIONS

To turn on the unit, plug the power cord into the wall, flip oven down into cooking position, and press the  button.

NOTE: The unit preheats more quickly, so we recommend prepping all ingredients before turning on the oven.

AIR FRY

- 1 To select the function, press MODE, then turn the dial until AIR FRY illuminates. The default time and temperature settings will display.
- 2 Press the TIME/SLICES button and use the dial to select your time up to 1 hour. Time will adjust in 1-minute increments under 1 hour. To set the time, press the TIME/SLICES button again.
- 3 Press the TEMP/SHADE button and use the dial to select a temperature between 250°F and 450°F. Temperature will adjust in 5-degree increments. To set the temperature, press the TEMP/SHADE button again.
- 4 Press the setting dial to begin preheating.
- 5 Place ingredients in the air fry basket. If ingredients are fatty, oily, or marinated, place the basket on the top rails and the sheet pan and wire rack on the bottom rails.

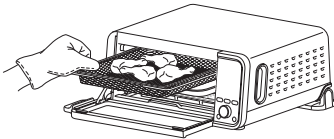

Use air fry basket for dry ingredients.

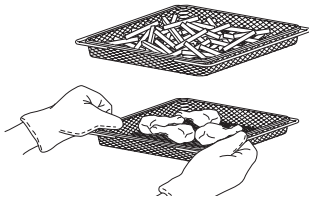

Use air fry basket with sheet pan underneath for fatty, oily, or marinated ingredients. When using the sheet pan underneath, you may need to flip food over halfway through cooking for more even cooking.

- 6 When the unit beeps to signify it has preheated, immediately slide the basket into the upper rails of the oven. If also using the sheet pan, slide the sheet pan on wire rack into the bottom rails.

NOTE: The timer will start counting down as soon as the unit has preheated. If ingredients are not ready to go into the oven, simply turn the dial to add more time.

- 7 For more even browning and crispiness, flip ingredients using non-metal tongs or spatula halfway through cooking cycle.
- 8 When cook time is complete, the unit will beep and "END HOT" will appear on the display.

BROIL

- 1 To select the function, press the MODE button, then turn the dial until BROIL illuminates. The default time and temperature settings will display.
- 2 Press the TIME/SLICES button and use the dial to select your time up to 30 minutes. Time will adjust in 30-second increments. To set the time, press the TIME/SLICES button again.
- 3 Press the TEMP/SHADE button and use the dial to select either HI (500°F) or LO (400°F). To set the temperature, press the TEMP/SHADE button again.

NOTE: There is no preheat for the Broil function.

- 4 Place ingredients on the sheet pan. Place the sheet pan on the wire rack on bottom rails. Close oven door. Press the setting dial to begin cooking.

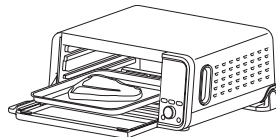

- 5 During cooking, you can open the oven door to check on or flip ingredients.

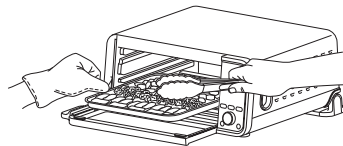

- 6 When cook time is complete, the unit will beep and "END HOT" will appear on the display.

AIR ROAST

- 1 To select the function, press the MODE button, then turn the dial repeatedly until AIR ROAST illuminates. The default time and temperature settings will display.
- 2 Press the TIME/SLICES button and use the dial to select your time up to 2 hours. Time will adjust in 1-minute increments under 1 hour and 5-minute increments over 1 hour. To set the time, press TIME/SLICES button again.
- 3 Press the TEMP/SHADE button and use the dial to select a temperature between 250°F and 450°F. Temperature will adjust in 5-degree increments. To set the temperature, press the TEMP/SHADE button again.
- 4 Press the setting dial to begin preheating. Place ingredients on the sheet pan.

NOTE: Food cooks faster when using the Air Roast function than when using the Bake function, so for traditional oven recipes, refer to the Inspiration Guide for guidance on cook times and temperatures.

- 5 When the unit beeps to signify it has preheated, immediately open the oven door and place the sheet pan on the wire rack on bottom rails. Close oven door.

NOTE: The timer will start counting down as soon as the unit has preheated. If ingredients are not ready to go into the oven, simply turn the dial to add more time.

- 6 During cooking, you can open the oven door to check on or flip ingredients.

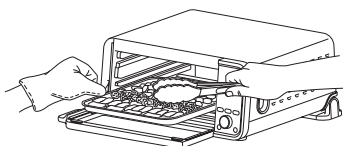

- 7 When cook time is complete, the unit will beep and "END HOT" will appear on the display.

BAKE

NOTE: Use recommended times and temperatures with boxed foods. Time and temperature will vary when using different types of baking accessories from box instructions.

- 1 To select the function, press the MODE button, then turn the dial until BAKE illuminates. The default time and temperature settings will display.
- 2 Press the TIME/SLICES button and use the dial to select your time up to 2 hours. Time will adjust in 1-minute increments under 1 hour and 5-minute increments over 1 hour. To set the time, press the TIME/SLICES button again.
- 3 Press the TEMP/SHADE button and use the dial to select a temperature between 250°F and 450°F. Temperature will adjust in 5-degree increments. To set the temperature, press the TEMP/SHADE button again.
- 4 Press the setting dial to begin preheating.

NOTE: If using another baking accessory, slide the wire rack into the bottom rails with the accessory on top.

NOTE: The timer will start counting down as soon as the unit has preheated. If ingredients are not ready to go into the oven, simply turn the dial to add more time.

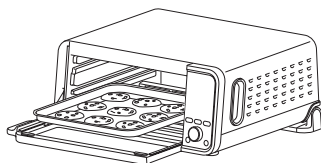

- 5 Place ingredients on the sheet pan. When the unit beeps to signify it has preheated, immediately place the sheet pan on wire rack into the bottom rails. Close oven door.

NOTE: You can also manually adjust the time once cooking has started to better achieve your preferred shade.

- 6 During cooking, you can open the oven door to check on or flip ingredients.
- 7 When cook time is complete, the unit will beep and "END HOT" will appear on the display.

USING YOUR NINJA® FLIP 10-IN-1 TOASTER OVEN & AIR FRYER

PIZZA

- 1 To select the function, press the MODE button, then turn the dial until PIZZA illuminates. The default time and temperature settings will display.
- 2 Press the TIME/SLICES button and use the dial to select your time up to 2 hours. Time will adjust in 1-minute increments under 1 hour and 5-minute increments over 1 hour. To set the time, press the TIME/SLICES button again.
- 3 Press the TEMP/SHADE button and use the dial to select a temperature between 180°F and 500°F. Temperature will adjust in 5-degree increments. To set the temperature, press the TEMP/SHADE button again.
- 4 Press the setting dial to begin preheating.
- 5 Place ingredients on the sheet pan or wire rack. When the unit beeps to signify it has preheated, immediately place the sheet pan on wire rack into the bottom rails. Close oven door.

NOTE: The timer will start counting down as soon as the unit has preheated. If ingredients are not ready to go into the oven, simply turn the dial to add more time.

- 6 During cooking, you can open the oven door to check on ingredients.
- 7 When cook time is complete, the unit will beep and "END HOT" will appear on the display.

TOAST

- 1 To select the function, press the MODE button, then turn the dial until TOAST illuminates. The default amount of slices and shade will be displayed.
- 2 Press the TIME/SLICES button and use the dial to select the number of bread slices. You may toast up to 9 slices at once. To set the number of slices, press the TIME/SLICES button again.
- 3 Press the TEMP/SHADE button and use the dial to select a shade level. To set the shade level, press the TEMP/SHADE button again.

NOTE: There is no temperature adjustment available for the Toast function, and the unit does not preheat in Toast mode. It is very important to select the exact number of slices to avoid over- or under-toasting. Results may vary when unit is already warm.

- 4 Place bread slices on the wire rack into middle rails. Close oven door and press the setting dial to begin cooking. You do not need to flip the slices during cooking.
- 5 When cook time is complete, the unit will beep and "END HOT" will appear on the display.

NOTE: You can also manually adjust the time once cooking has started to better choose your preferred shade.

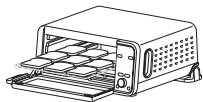

BAGEL

- 1 To select the function, press the MODE button, then turn the dial until BAGEL illuminates. The default number of slices and shade level will display.
- 2 Press the TIME/SLICES button and use the dial to select the number of slices. You may toast up to 6 bagel halves at once. To set the number of slices, press the TIME/SLICES button again.
- 3 Press the TEMP/SHADE button and use the dial to select a shade level. To set the shade level, press the TEMP/SHADE button again.

NOTE: There is no temperature adjustment available for the Bagel function, and the unit does not preheat in Toast mode. It is very important to select the exact number of slices to avoid over- or under-toasting. Results may vary when unit is already warm.

- 4 Place bagel slices, cut-side up, on the wire rack into middle rails. Close oven door and press the setting dial to begin cooking. You do not need to flip the slices during cooking.

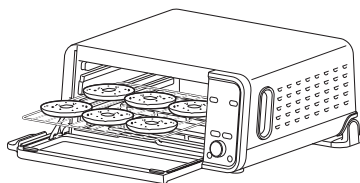

- 5 When cook time is complete, the unit will beep and "END HOT" will appear on the display.

NOTE: You can also manually adjust the time once cooking has started to better achieve your preferred shade.

REHEAT

NOTE: The REHEAT function is not included on all models.

- 1 To select the function, press the MODE button, then turn the dial until REHEAT illuminates.
- 2 Press the TIME/SLICES buttons to select a reheat time up to 2 hours. Time will adjust in 1-minute increments under 1 hour and 5-minute increments over 1 hour.
- 3 Press the TEMP/SHADE button to select a temperature between 100°F and 450°F. Temperature will adjust in 5-degree increments.
- 4 Place food on the sheet pan or in an oven-safe container and place the pan or container on the wire rack into the bottom rails. Close oven door and press the setting dial to begin cooking.
- 5 When cook time is complete, the unit will beep and "END HOT" will appear on the display.

NOTE: There is no preheat with Reheat.

DEHYDRATE

NOTE: The DEHYDRATE function is not included on all models.

- 1 To select the function, press the MODE button, then turn the dial until DEHYDRATE illuminates. The default time and temperature settings will display.
- 2 Press the TIME/SLICES button and use the dial to select a time up to 12 hours. Time will adjust in 15-minute increments. To set the time, press the TIME/SLICES button again.

NOTE: There is no preheat with Dehydrate.

- 3 Press the TEMP/SHADE button and use the dial to select a temperature between 85°F and 200°F. Temperature will adjust in 5-degree increments. To set the temperature, press the TEMP/SHADE button again.
- 4 Place ingredients in the air fry basket and place basket into top rails of oven. Close oven door and press the setting dial to begin cooking.

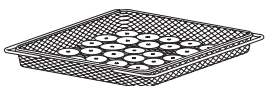

- 5 During cooking, you can open the oven door to check on or flip ingredients halfway through cooking.
- 6 When cook time is complete, the unit will beep and "END HOT" will appear on the display.

KEEP WARM

- 1 To select the function, press MODE, then turn the dial until KEEP WARM illuminates. The default time setting will display.
- 2 Press the TIME/SLICES button and use the dial to select a time up to 2 hours. To set the time, press the TIME/SLICES button again.

NOTE: There is no temperature selection available for the Keep Warm function.

- 3 Place food on the sheet pan or in an oven-safe container and place the pan or container on the wire rack on bottom rails. Close oven door and press START/STOP to begin warming.
- 4 When warming time is complete, the unit will beep and "END HOT" will appear on the display.

NOTE: The unit does not preheat in Keep Warm mode.

CLEANING, MAINTENANCE & STORAGE

EVERYDAY CLEANING

The unit should be cleaned thoroughly after every use.

- 1 Unplug the unit from the outlet and allow it to cool down before cleaning.
- 2 Empty crumb tray by sliding it out of the oven when the oven is in the flipped-down position. Clean accessories after each use. Accessories are hand-wash recommended. The air fry basket and wire rack can be put in the dishwasher, but may wear more quickly over time. **DO NOT** place sheet pan in dishwasher.
- 3 To clean any food splatter on the interior walls of the unit, wipe them with a soft, damp sponge. **DO NOT** use abrasive cleaners, scrubbing brushes, or chemical cleaners, as they will damage the oven.

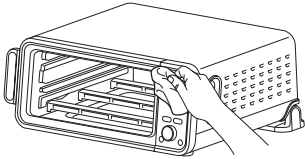

NOTE: Empty crumb tray frequently. Hand-wash when necessary.

- 4 To clean the exterior of the main unit and the control panel, wipe them clean with a damp cloth. A non-abrasive liquid cleanser or mild spray solution may be used. Apply the cleanser to the sponge, not the oven surface, before cleaning.

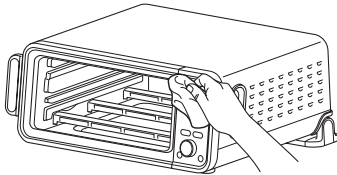

NOTE: **DO NOT** submerge unit in water or place in dishwasher.

DEEP CLEANING

- 1 Allow the unit to cool down, then unplug the unit from the outlet before cleaning.
- 2 Remove all accessories from the unit, including the crumb tray, and wash separately. Use a non-abrasive cleaning brush to wash the air fry basket more thoroughly. Soak accessories overnight in hot, soapy water. The air fry basket and wire rack can be put in the dishwasher, but may wear more quickly over time.
- 3 Use warm, soapy water and a soft cloth to wash the oven's interior. **DO NOT** use abrasive cleaners, scrubbing brushes, or chemical cleaners, as they will damage the oven.

NOTE: **NEVER** put the main unit in the dishwasher or immerse it in water or any other liquid.

- 4 To prolong use of accessories, hand-wash with warm, soapy water.
- 5 Thoroughly dry all parts before placing them back in the oven.

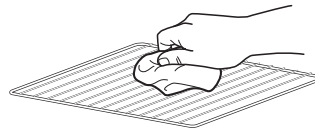
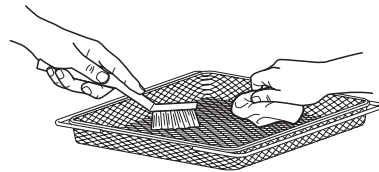

NOTE: The unit does not preheat in Keep Warm mode.

FLIP-UP-AND-AWAY STORAGE

- 1 DO NOT** flip unit up when it is hot or in use. FLIP will appear on the display when unit is cooled and ready to flip. Wait for unit to cool down before handling. Hold handles on each side of the unit. **DO NOT** unplug the unit after use until FLIP appears. The fan will continue to run after cooking has completed for about 15 minutes or until the unit's temperature is 95°F. This is normal and not a cause for concern.

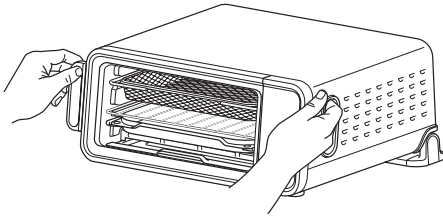

- 2** Lift and flip unit upward using the handles on each side of the unit.

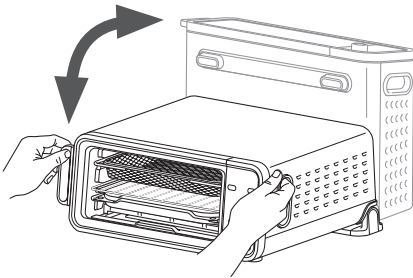

- 3** Leave the unit in the upright position when storing or for deep cleaning. Accessories can be stored inside while in the upright position. See Accessory Storage Placement section on page 5 for correct placement.

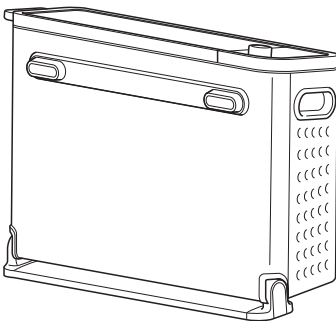

ACCESSORIES FOR PURCHASE

We offer a suite of accessories custom made for your Ninja® Flip 10-in-1 Toaster Oven & Air Fryer. Visit ninjaccessories.com to expand your capabilities and take your cooking to the next level.

- Egg Bite/Muffin Tray

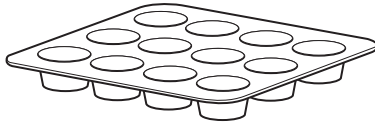

- Broiling Rack

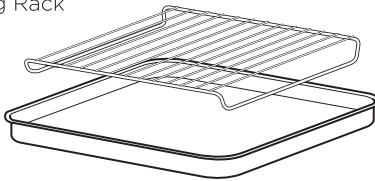

- 2" Casserole Dish

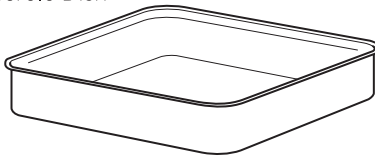

- Multi-Purpose Pan



- Mini Morsel Tray

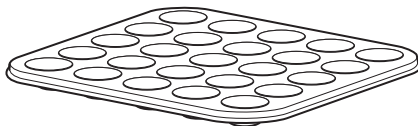

TROUBLESHOOTING & FAQ

ERROR MESSAGES

“Er0,” “Er1,” “Er2,” “Er3,” “Er4,” “Er5,” “Er6,” or “Er7”

Power off the unit and call Customer Service at **1-877-646-5288**. So we may better assist you, please register your product online at registryourninja.com and have the product on hand when you call.

FAQ

Why won't the oven turn on?

- Oven needs to be in flipped-down position in order to power it on.
- Make sure the power cord is securely plugged into the outlet.
- Insert the power cord into a different outlet.
- Reset the circuit breaker if necessary.
- Press the power button.

Can I use the Sheet Pan instead of the air fry basket with air fry function?

- Yes, but flipping ingredients during cooking is required, and levels of crispiness may vary.

Do I need to adjust the cook times and temperatures of traditional oven recipes?

- For best results, keep an eye out on your food while cooking. Refer to cook charts in the Inspiration Guide for more guidance on cook times and temperatures.

Should I add my ingredients before or after preheating?

- Adding ingredients before preheat completes may impact cooking performance.

Why is my food undercooked or overcooked?

- Do not add food until recommended preheat time is complete. For best results, check progress throughout cooking, and remove food if desired level of brownness has been achieved. Remove food immediately after the cook time is complete to avoid overcooking.
- This unit cooks faster than a traditional oven. Always keep an eye on your food while cooking.

Can I restore the unit to its default settings?

- The oven will remember the last setting used for each function, even if you unplug it. To restore the oven's default settings for each function, press the TIME/SLICE and TEMP/SHADE buttons simultaneously for 5 seconds.

Why do the heating elements appear to be turning on and off?

- This is normal. The oven is designed to control temperature precisely for every function by adjusting the heating elements' power levels.

Why is steam coming out from the oven door?

- This is normal. The door is vented to release steam created by foods with a high moisture content.

Why is water dripping onto the counter from under the door?

- This is normal. The condensation created by foods with a high moisture content (such as frozen breads) may run down the inside of the door and drip onto the counter.

Why is there noise coming from the control panel or back of unit?

- When the oven is hot, a fan turns on to cool down the control panel.

Why does the unit sound like it is still running even though the power is off?

- The cooling fan may continue to run even after the unit has been turned off. This is a normal function and should not be a source of concern. The cooling fan will stop after the temperature of the unit is below 95°F.

REPLACEMENT PARTS

To order additional parts and accessories, visit ninjaaccessories.com or contact Customer Service at **1-877-646-5288**. So we may better assist you, please register your product online at registryourninja.com and have the product on hand when you call.

The One (1) Year Limited Warranty applies to purchases made from authorized retailers of **SharkNinja Operating LLC**. Warranty coverage applies to the original owner and to the original product only and is not transferable.

SharkNinja warrants that the unit shall be free from defects in material and workmanship for a period of one (1) year from the date of purchase when it is used under normal household conditions and maintained according to the requirements outlined in the Owner's Guide, subject to the following conditions and exclusions:

What is covered by this warranty?

1. The original unit and/or non-wearable parts deemed defective, in SharkNinja's sole discretion, will be repaired or replaced up to one (1) year from the original purchase date.
2. In the event a replacement unit is issued, the warranty coverage ends six (6) months following the receipt date of the replacement unit or the remainder of the existing warranty, whichever is later. SharkNinja reserves the right to replace the unit with one of equal or greater value.
California Residents Only: The One (1) Year Limited Warranty period begins on the original date of delivery or pickup.

What is not covered by this warranty?

1. Normal wear and tear of wearable parts (such as blending vessels, lids, cups, blades, blender bases, removable pots, racks, pans, etc.), which require regular maintenance and/or replacement to ensure the proper functioning of your unit, are not covered by this warranty. Replacement parts are available for purchase at ninjaaccessories.com.
2. Any unit that has been tampered with or used for commercial purposes.
3. Damage caused by misuse, abuse, negligent handling, failure to perform required maintenance (e.g., failure to keep the well of the motor base clear of food spills and other debris), or damage due to mishandling in transit.
4. Consequential and incidental damages.
5. Defects caused by repair persons not authorized by SharkNinja. These defects include damages caused in the process of shipping, altering, or repairing the SharkNinja product (or any of its parts) when the repair is performed by a repair person not authorized by SharkNinja.
6. Products purchased, used, or operated outside North America.

How to get service

If your appliance fails to operate properly while in use under normal household conditions within the warranty period, visit ninjakitchen.com/support for product care and maintenance self-help. Our Customer Service Specialists are also available at **1-877-646-5288** to assist with product support and warranty service options, including the possibility of upgrading to our VIP warranty service options for select product categories. So we may better assist you, please register your product online at registeryourninja.com and have the product on hand when you call.

SharkNinja will cover the cost for the customer to send in the unit to us for repair or replacement. A fee of \$20.95 (subject to change) will be charged when SharkNinja ships the repaired or replacement unit.

How to initiate a warranty claim

You must call **1-877-646-5288** to initiate a warranty claim. You will need the receipt as proof of purchase. We also ask that you register your product online at registeryourninja.com and have the product on hand when you call, so we may better assist you. A Customer Service Specialist will provide you with return and packing instruction information.

How state law applies

This warranty gives you specific legal rights, and you also may have other rights that vary from state to state. Some states do not permit the exclusion or limitation of incidental or consequential damages, so the above may not apply to you.

